

Ishida Europe: understanding and tackling the weighing and packing line challenges you face

- Unique engineering expertise, combined with practical industry knowledge in your sector
- Global applications experience, including snacks, meat, poultry, ready meals, fresh produce, dry and frozen foods, bakery, confectionery and pasta
- R&D resources and commitment to support both continuous improvement and major innovation
- Solutions include consultancy and project management, complete packing lines, multihead weighers, distribution and topping systems, X-Ray inspection systems, snackfood bagmakers, checkweighers, tray sealers, weigh-price-labellers and pick-and-place systems.



Working with you every step of the way

Our extensive R&D investment is directed at meeting the challenges of the fast-changing food industry around the globe.

We aim to support our partners fully, from the very start of the buying process, and you will find many equipment brochures, visual animations and case studies available on our website. When you are ready to make contact, a well-resourced network of Ishida companies, distributors and agents, extending across Europe, the Middle East and Africa, can provide advice and organise demonstrations and trials.

Installation is rapid and efficient. For integrated packing lines, we use proven project management techniques and methodologies, tuned to your key objectives and specifications.

A dedicated pan-European service engineering team helps to maximise the performance, functionality and reliability of our installed base. In addition, spares facilities are strategically placed throughout the territory, offering 24-hour delivery in most cases.



helpline • spares • service • training



ISHIDA EUROPE LIMITED
Kettles Wood Drive
Woodgate Business Park
Birmingham
B32 3DB
United Kingdom
Tel: +44 (0)121 607 7700
Fax: +44 (0)121 607 7888
info@ishidaeurope.com

ISHIDA CZECH REPUBLIC
Tel: +420 317 844 059
Fax: +420 317 844 052
info@ishidaeurope.cz

ISHIDA ROMANIA
Tel: +40 (0)21 589 73 52
Fax: +40 (0)21 310 34 22
info@ishidaeurope.ro

ISHIDA FRANCE
Tel: +33 (0)1 48 63 83 83
Fax: +33 (0)1 48 63 24 29
info@ishidaeurope.fr

ISHIDA RUSSIA AND CIS
Tel: +7 499 272 05 36
Fax: +7 499 272 05 37
info@ishidaeurope.ru

ISHIDA GERMANY
Tel: +49 (0)791 945 160
Fax: +49 (0)791 945 1699
info@ishida.de

ISHIDA SOUTH AFRICA
Tel: +27 (0)11 976 2010
Fax: +27 (0)11 976 2012
info@ishidaeurope.com

ISHIDA MIDDLE EAST
Tel: +971 (0)4 299 1933
Fax: +971 (0)4 299 1955
ishida@ishida.ae

ISHIDA SWITZERLAND
Tel: +41 (0)41 799 7999
Fax: +41 (0)41 790 3927
info@ishida.ch

ISHIDA NETHERLANDS
Tel: +31 (0)499 39 3675
Fax: +31 (0)499 39 1887
info@ishida.nl

FF-series

High performance fresh food weighers



FF-series

Automatic weighing solutions for fresh foods - minimum waste, maximum payback!

Ishida has extensive experience in creating systems that use the combination weighing principles to weigh and pack a wide variety of fresh foods with the highest accuracy and consistency.

Combining state-of-the-art weighing technology with unmatched precision and proven reliability, Ishida provides solutions that minimise waste, maximise efficiency, save time, and reduce labour - plus they are simple to operate and easy to clean.

The Ishida fresh food weighers have the versatility to handle a wide variety of products and customer requirements.

All seven models are ideal for difficult to handle, sticky products and short production runs, where fast product changeovers are essential.



Easy product handling for maximum production efficiency

All hoppers utilise sliding doors. These easily dislodge product residues so that sticky products can be handled comfortably.

All plastic hoppers are made of resin and the inner walls are rippled to prevent product sticking.

The collection belt conveyors are fitted with scraper gates. These remove product residues to ensure a reliable and precise product discharge.

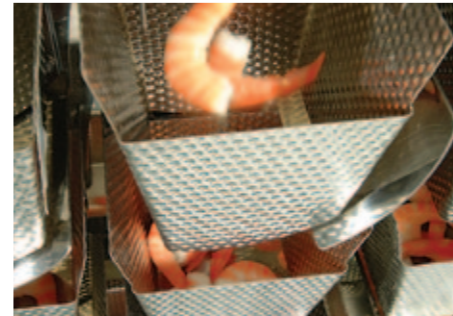

Accuracy and consistency minimise product giveaway

For most applications a product giveaway of only 0.5g or less than 1% can be achieved with consistent high weighing speeds up to 70 packs per minute.

The high level of consistency ensures that the production output is stabilised.



The economic solution

Manual operation typically requires 5 operators to weigh the product on static scales and to fill the pack. The Ishida fresh food weighers require no more than 2 operators thus saving up to 5 operators per shift.

Automatic product feeding is an option that further reduces the number of operators required.

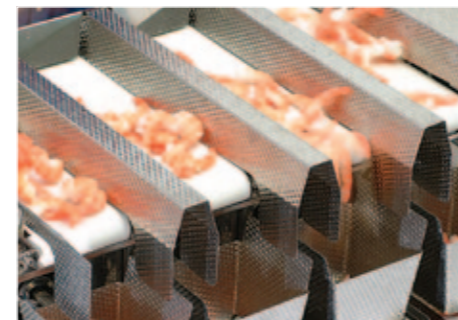

Simple operation

The linear feeders act as a product buffer between the infeed system and the pool hoppers. This makes manual operation considerably easier.

Pool hoppers can be specified with loadcells for easy product detection. This allows a degree of random product feed to the pool hoppers and makes manual operation stress-free.

The user friendly touch screen Remote Control Unit (RCU) requires minimal operator training. Up to 50 pre-sets can be stored in the RCU memory for quick machine set-up and product changeover.



Easy cleaning

A waterproof, hygienic construction allows for thorough cleaning of the main body and contact parts.

The need for minimum hand intervention ensures compliance with the strictest hygiene standards (such as HACCP).

All contact parts can be easily removed, cleaned and replaced without using tools. This minimises downtime.



Maximum payback

Minimum product waste, consistently high productivity and high savings on labour mean that typical payback periods can be reduced to just a few months.



Applications include: poultry, meat, fish, fruit, salad, vegetables, rice, pasta, ready meals

Technical specification

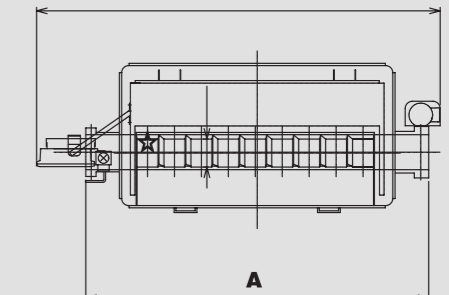
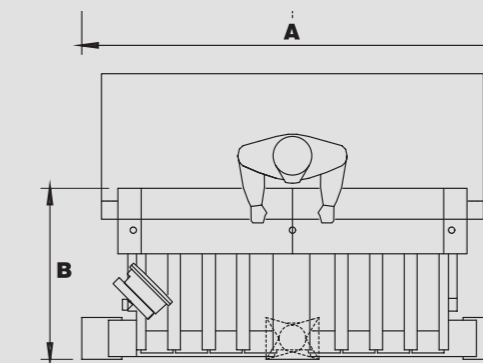
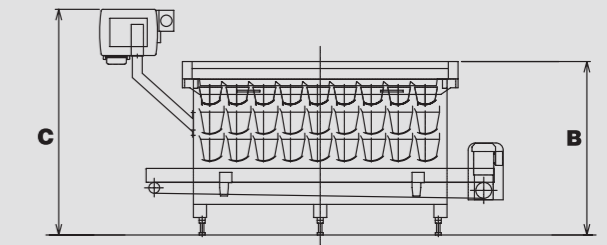
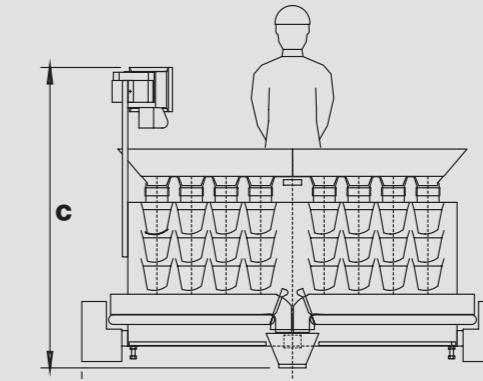

***Dimensions shown are for 9-head model only

Model	A (max)	B (max)	C (max)	Weighing volume (max) (per single discharge)	Weighing capacity (per single discharge)	Weighing speed (max)*
5-head	1235	900	1510	2.0L	1kg	25 wpm
6-head	1395	900	1510	2.5L	1kg	35 wpm
8-head	2315	940	1600	3.5L	3kg	40 wpm
9-head***	1960	985	1285	3.5L	3kg	30 wpm
10-head**	2260	900	1510	2.5L	1kg	40 wpm
10-head	2260	900	1510	2.5L	1kg	60 wpm
12-head	2580	900	1510	2.5L	1kg	70 wpm

Dimensions shown are for guidance only and depend on chosen options
 *Depends on target weight, product shape, product density and other weighing conditions
 **Specified with only one set of weigh hoppers

Whatever you make, **make certain.**

FF-series