

# Technical specification

## Dimensions (Unit: mm)

Incline infeed conveyor model

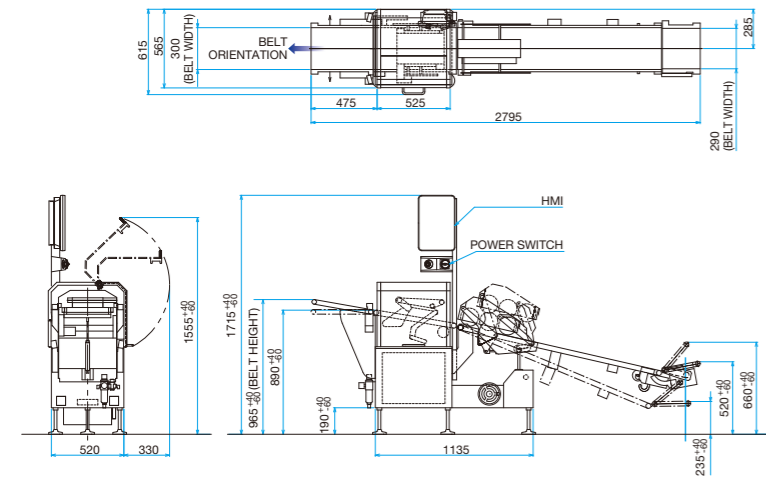

Horizontal infeed conveyor model

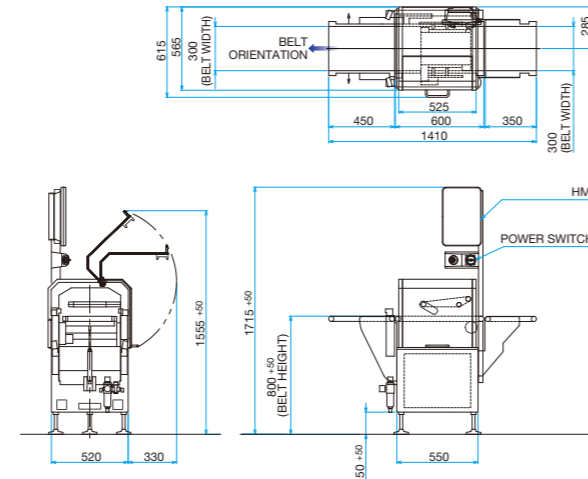

## Specifications

Model	TSC-AS	
Inspection thickness capacity (MAX)	15-120mm	
Bag size handling	Length	100-600mm
	Width	50-300mm
	Thickness	15-120mm
Inspection speed (MAX) <sup>1)</sup>	150bpm	
Inspection accuracy <sup>2)</sup>	3mm or more pinhole	
Belt speed <sup>3)</sup>	15-85m/min	
HMI	15.6" color LCD touch panel	
Number of presets	500 items	
Power Supply <sup>4)</sup>	1-phase 200V 500W 5.0A	
Rejector	Air jet Three-way + Drop belt	
	Air jet Three-way	
Air Consumption	Air jet rejector 10ℓ (ANR)	
	Drop belt rejector 2ℓ (ANR)	
Material and finish	Iron (Metallic gray painted)	
Ingress protection <sup>5)</sup>	IP 30	
Operating environment	Temperature	0-40°C
	Humidity	30~85%RH (without dew condensation)
Weight	Approx. 210kg	

\*1) Running condition will depend on belt speed, product shape and condition  
 \*2) Depending on product shape and condition  
 \*3) Configurable 1m/min interval  
 \*4) Voltage fluctuation : within ±10%  
 \*5) Based on internal test results

The information in this catalog is current as of May 23, 2023.  
 The company name and product name described in this catalog are registered trademarks.  
 The machine color in this catalog might be differ from the real machine.  
 The described machine appearance and specifications in this catalog are subject to change without any notification.



ISHIDA CO.,LTD. [www.ishida.com](http://www.ishida.com)

44 Shogoin Sannocho, Sakyo-ku,  
 Kyoto, 606-8392, Japan  
 Tel: +81 (0)75 751 1618 Fax: +81 (0)75 751 1634



Thickness and Seal checker

# TSC-AS



# Checking each pack for leaks and pack thickness Achieves quality improvement and saves manpower

Servo motor control allows optimum adjustment of inspection head for accuracy inspection.

Precise inspection

Inspects air leakage and pack thickness with high accuracy, and contributes to the reduction of claims.

Easy operation

Intuitive operation from a HMI screen  
Fully automatic changeover is available at a touch of a button

Simple and flexible machine design

Easy to clean machine design allows better accessibility and reduces maintenance downtime.



Automatic changeover Option

Fast fully automatic changeover without the need for tools, simple operation via a preset. Increased productivity reducing machine downtime and eliminating human error.

Changeover operation time  
**Less than 1 minute**

Inspection performance

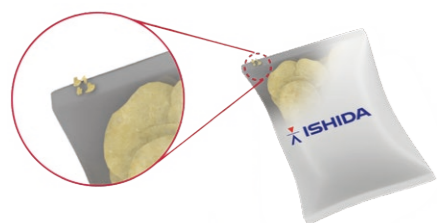

**Chip-in-seal**  
Inspects air leakage by chip-in-seal.

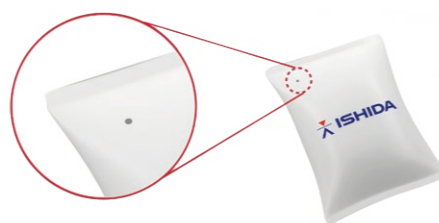

**Pinhole**  
Inspects pinhole made by physical contact. 3mm diameter hole is detectable with 150bpm.

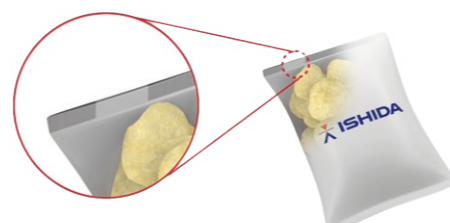

**Sealing quality**  
Defective sealing quality by poor heat sealing.

Hygienic and accessible design

Whilst providing good and clear access the fixed position of this cover avoids any interference with up or down stream equipment as opposed to the use of a sliding cover.



Sloping design prevents dust build up.

Up-stream and down-stream communication

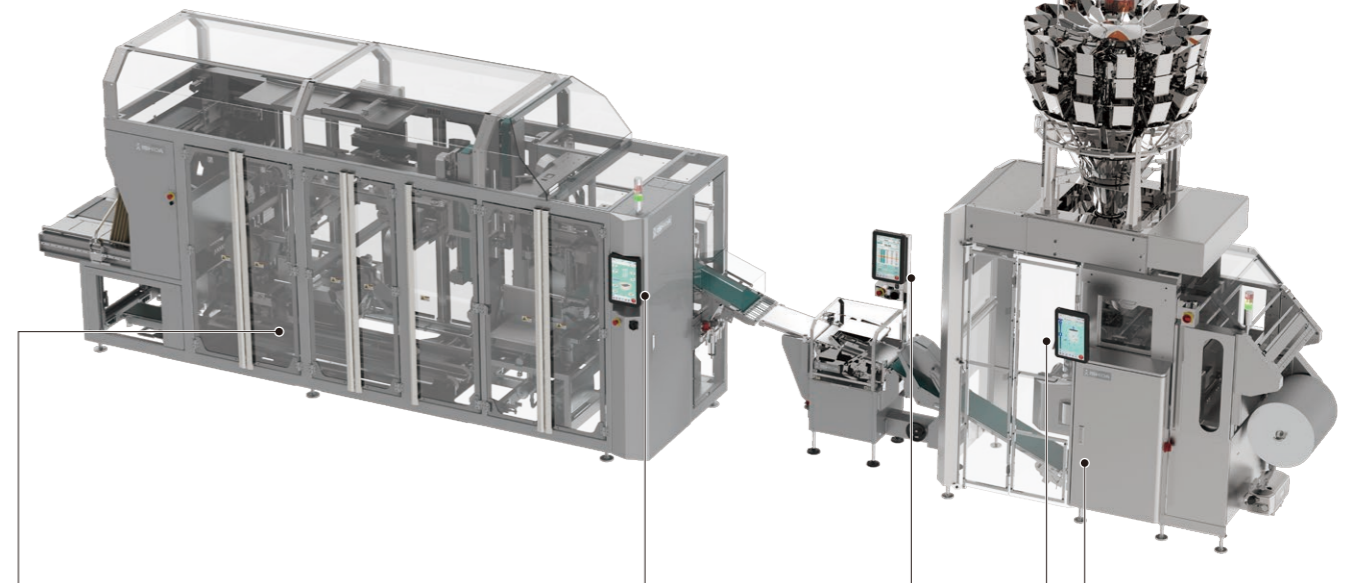

**Down-stream**

The TSC-AS can feed-forward air-fill data to the Ishida ACP-700 series case packer allowing adjustments to be made preventing the likelihood of packs being miss-fed.

**Complete line control from one HMI**

Ishida ITPS-2 software allows full in-line control and access to each machine from one single HMI.

**Single command product change**

Complete line change can be performed from any of the machine HMI's within the same line providing for a fast any error free product changeover without the requirement of a skilled operator.

**Up-stream**

The TSC-AS can measure and feed-back airfill data directly to the Ishida bagmaker allowing automatic adjustment of the jaw to maintain a constant pack thickness.

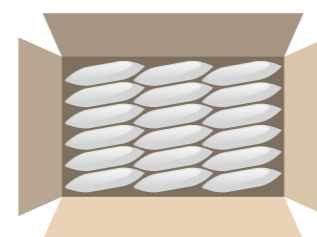

With TSC

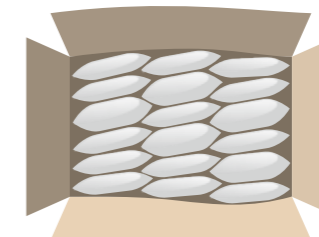

Without TSC

