



CCW-RV-214W-1S-30-WP-QFP1

Dedicated range of automated, high speed, accurate weighing solutions specifically designed for handling **FROZEN MEAT** and **FISH**.

The RV series from Ishida represents the latest state of the art multihead weighing performance for speed, accuracy and reliability and comes with the industry's leading high performance specification as standard.

This multihead weigher is designed specifically for high speed weighing of smaller target weights of frozen meat - typically with smaller piece sizes such as small seafood, chicken nuggets or meat balls. It also includes an independently certified IP69K test rating – ideally suited to the most challenging frozen and wet weighing and packaging environments.

The Ishida frozen protein weighers have been thoroughly tested to ensure Ishida customers receive the best in class solution for this challenging application.

Dimensions

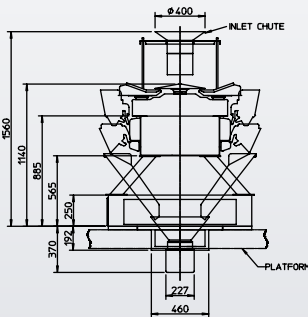
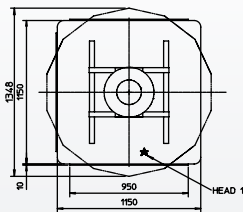

(With TH)

Specifications	CCW-RV-214W-1S-30-WP-QFP1	
Weighing Capacity (per head)	400g	800g
Maximum Volume for Weighing (per dump)	4.5 litres	
Weighing Speed (variable dependent on specific product and target weight)	100 WPM	
Minimum Graduation	0.1g	0.2g
Touch Screen 3D Graphical Display (RCU)	12.1" Colour LCD display including printer (as standard)	
Weigh Cell	Ishida double-beam loadcell	
Vibration control on DFT and RFTs	Pulse width modulation (precise and programmable vibration frequency control - independent from input frequency)	
Number of Presets	200	
Materials	Hex embossed 304 stainless steel contact parts	
Machine Weight	Approx. 550kg	
Options	This frozen protein weigher model is a fixed high specification solution dedicated to the specific industry requirements (see specific model details)	
IP test rating of structure	Tested and independently certified to IP69K (see specific wash down instructions in operators manual)	
Air consumption (waterproof machines)	110 litres/min (ANR) 0.5 MPa Air hose - PT 3/8" (for dryer connection) Note: Air hose compressor must be provided by the end user	
Power consumption	0.5kW	
Standard compliance	Ce/UL/FDA/USDA/RoHS	

Design and specifications are subject to change without notice (please confirm dimensions at point of order).



CCW-RV-214W-1S-30-WP-QFP1



RV FROZEN MEAT 1

Features and benefits



Part of a dedicated range of automated, high speed, accurate weighing solutions specifically designed for handling frozen meat using Ishida's unrivalled industry experience.

No other multihead weigher supplier can match the experience and global installed base of Ishida and it is this expertise and sector-specific knowledge that has gone into the frozen meat solution.

The frozen meat solution is based on the highest performance RV series multihead weigher platform – this has then been configured for optimum performance for this sector.

Detailed analysis of historic installations, combined with Ishida's expert team of design and application specialists has resulted in the creation of this range of high performance sector solutions.

RV high performance features

- Capable of using all 14 heads in a single combination calculation = 16383 combinations (for maximum efficiency and minimum product giveaway per cycle)
- Simultaneous triple combination calculation (delivering up to 100% efficiency)
- 5 stage digital filter (rapid stable calculations)
- Pulse width modulation on individual radial feeders (precise programmable vibration control to achieve harmonic frequency per radial feeder - independent of input frequency for unrivalled product-specific in-feed control)
- Average weight control software internal calculation resolution to 0.01g (minimise giveaway every cycle)
- Anti-floor vibration with 4 load cells (remove back ground vibration noise from load cell calculation for maximum weighing accuracy and avoiding product giveaway or missed cycles)
- 12.1" remote control unit (RCU) - (large clear screen for rapid programmable control)
- RCU cover as standard (reduce risk of screen damage for long life)
- 200 different product pre-sets (flexible and ensures rapid product changeovers)
- 3D screen display with immediate screen refresh rates (clear intuitive data display to assist operator to continuously monitor and adjust machine performance)
- Ethernet connection - to data link machine performance to customers local area network and internal management systems
- Printer for hard copy read out
- USB access for alternative data capture and transfer
- All materials are FDA approved and comply with Article 16 (1) of Regulation (EC) number 1935/2004, and Article 15 of Regulation 10/2011

Model	FROZEN MEAT 1 - CCW-RV-214W-1S-30-WP-QFP1	
Max Piece Length	130mm	
Target Volume*	< 1.35 litres	> 3.15 litres
Top Speed*	100 WPM	40 WPM
Contact Parts Finish	Hex embossed contact parts (to promote free flow of product) and reinforced components (for frozen products) Liners included for particularly fragile products	
Dispersion Table	Reinforced 10° and 20° for product flexibility (accounts for varying fragility or stickiness of product)	
Ring Gate	Included with blue metal-detectable polyurethane fingers (controlling product infeed)	
Radial Feeder Troughs	Standard shape radial troughs design to control small target weights of frozen meat	
Hoppers	Double opening hoppers (for rapid product transfer of frozen product)	
Discharge Chutes	53° discharge chute with anti-swirl fins for increased product control and blue metal-detectable polyurethane cushion pipe to reduce product collisions (faster transfer)	
Timing Hopper	6 litres timing hopper included, pneumatically driven to protect against freezing Options: Double opening, diverting or error diverting	
Software	Multiple languages available, count priority, enhanced average weight control, error signal output, auto zero cleaning mode	

*figures are based on historical application products and may vary depending on specific nature of product



ISHIDA EUROPE LIMITED

Kettles Wood Drive
Woodgate Business Park
Birmingham
B32 3DB
United Kingdom
Tel: +44 (0)121 607 7700
Fax: +44 (0)121 607 7888
info@ishidaeurope.com

ISHIDA CZECH REPUBLIC

Tel: +420 317 844 059
Fax: +420 317 844 052
info@ishidaeurope.cz

ISHIDA ROMANIA

Tel: +40 (0)21 589 73 52
Fax: +40 (0)21 310 34 22
info@ishidaeurope.ro

ISHIDA FRANCE

Tel: +33 (0)1 48 63 83 83
Fax: +33 (0)1 48 63 24 29
info@ishidaeurope.fr

ISHIDA RUSSIA AND CIS

Tel: +7 499 272 05 36
Fax: +7 499 272 05 37
info@ishidaeurope.ru

ISHIDA GERMANY

Tel: +49 (0)791 945 160
Fax: +49 (0)791 945 1699
info@ishida.de

ISHIDA SOUTH AFRICA

Tel: +27 (0)11 976 2010
Fax: +27 (0)11 976 2012
info@ishidaeurope.com

ISHIDA MIDDLE EAST

Tel: +971 (0)4 299 1933
Fax: +971 (0)4 299 1955
ishida@ishida.ae

ISHIDA SWITZERLAND

Tel: +41 (0)41 799 7999
Fax: +41 (0)41 790 3927
info@ishida.ch

ISHIDA NETHERLANDS

Tel: +31 (0)499 39 3675
Fax: +31 (0)499 39 1887
info@ishida.nl