

# Ultrasonic Snacks Packaging Technology

NEW! Atlas 204 Ultrasonic bagmaker  
World's first rotary ultrasonic snack food bagmaker up to 140bpm

The future of snacks packaging sealing technology is now available from Ishida – world leader in packaging solutions.

This ultrasonic bagmaker is the latest innovative technology developed to seal standard snacks OPP packaging film. Ultrasonic sealing offers significant operational advantages and savings:

- Film saving - ultra-narrow end seals (1.5 - 2.0mm)
- Reduced waste - improved seal integrity
- Reduced waste - increased seal strength
- Lower operating cost - reduced system energy consumption
- Enhanced machine safety - no residual system heat

When combined with the latest RV weighing solutions operating speeds of up to 140bpm are achieved. This World's first ultrasonic sealing bagmaker for snacks packaging continues to lead the market in packing performance whilst maintaining the highest operating efficiencies.



Specifications		
Model	Atlas-204 Ultrasonic	
Running Speed*	Up to 140bpm	
Bag Size	Width	75 - 280mm
	Length	75 - 533mm
Film size	Max Roll Width	483mm
	Bore of Film Roll Core	76.2mm
Product	Snack foods such as potato chips, corn chips, tortilla chips and popcorn	
Film Feeding Motion	Continuous	
Machine Size	Width	990mm
	Height	1825mm
	Length	1780mm
Net Weight	1200kg	
Operational Temperature	32-104°F (0-40°C) RH30-70% non condensing	
Sealing Jaw Motion	Twin rotary jaw -D action	

\*Actual maximum running speed depends on the product, product volume, packaging material and in-feed conditions  
Note: Design and specifications subject to change without notice

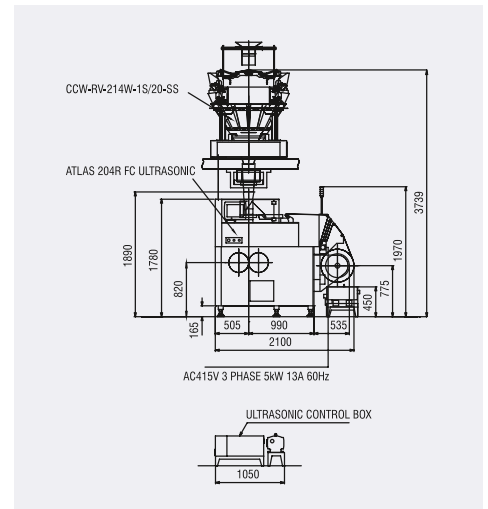

Atlas-204 Ultrasonic

# Features and benefits

## A quick payback

Because each item of equipment in the Ishida Range has been carefully engineered to provide improved productivity and value, it may cost you less than you think to enjoy the benefits of Ishida equipment. And typically, we find that payback can be covered over a period of months.

## Increased Sealing Quality

Ultrasonic sealing performance ensures that any potential product contamination of the seal area does not cause bag leakage due to the ultrasonic excitation effect across the seal area – it shakes the area clean. Internal ultrasonic heating ensures there is no film shrinkage around the seal. Increased seal strength allows bags produced at sea level to remain hermetically sealed when transported to higher altitudes.

## High accuracy – low giveaway

Excellent weighing accuracy dramatically reduces product giveaway when compared with conventional filling or dosing machines. The resulting cost savings mean that the average payback period is just a matter of months.

## Easy operation and set-up

The Remote Control Unit (RCU) with 10.4 inch colour touchscreen gives simplified, easy-to-follow operator interface, enabling quick set-up and rapid product changeovers.

## Consistent weighing results

A weight sensor in the dispersion table automatically adjusts the product feed, ensuring a consistent supply to the radial feeders. Each feeder can be individually adjusted via the RCU to optimise product feed. High quality stepper motors precisely control hopper gate opening and closing profiles for consistent weighing speed and accuracy.

## Combine with Ishida weighing for optimised results and single-source convenience

Ishida offers fully integrated, single manufacturer multihead weigher and bagmaker combinations for snacks. Years of experience with both machines have enabled Ishida to optimise the physical and electronic interfaces to enhance speed and reduce weightment spread. Equally important, one company takes full responsibility for the performance of the combination.

## Unbeatable support

Ishida Europe's comprehensive sales, service and spares support ensures that our weighers will reach you in perfect condition. Once installed to your complete satisfaction, it is backed by our industry leading technical support and our huge applications expertise.



### ISHIDA EUROPE LIMITED

Kettles Wood Drive  
Woodgate Business Park  
Birmingham  
B32 3DB  
United Kingdom  
Tel: +44 (0)121 607 7700  
Fax: +44 (0)121 607 7888  
info@ishidaeurope.com

### ISHIDA CZECH REPUBLIC

Tel: +420 317 844 059  
Fax: +420 317 844 052  
info@ishidaeurope.cz

### ISHIDA ROMANIA

Tel: +40 (0)21 589 73 52  
Fax: +40 (0)21 310 34 22  
info@ishidaeurope.ro

### ISHIDA FRANCE

Tel: +33 (0)1 48 63 83 83  
Fax: +33 (0)1 48 63 24 29  
info@ishidaeurope.fr

### ISHIDA RUSSIA AND CIS

Tel: +7 499 272 05 36  
Fax: +7 499 272 05 37  
info@ishidaeurope.ru

### ISHIDA GERMANY

Tel: +49 (0)791 945 160  
Fax: +49 (0)791 945 1699  
info@ishida.de

### ISHIDA SOUTH AFRICA

Tel: +27 (0)11 976 2010  
Fax: +27 (0)11 976 2012  
info@ishidaeurope.com

### ISHIDA MIDDLE EAST

Tel: +971 (0)4 299 1933  
Fax: +971 (0)4 299 1955  
ishida@ishida.ae

### ISHIDA SWITZERLAND

Tel: +41 (0)41 799 7999  
Fax: +41 (0)41 790 3927  
info@ishida.ch

### ISHIDA NETHERLANDS

Tel: +31 (0)499 39 3675  
Fax: +31 (0)499 39 1887  
info@ishida.nl