



CG-R-circular series

High speed, highly accurate granular weighing solution in circular format designed to suit conventional single or twin tube bag makers

For producers of granular, dry, free-flowing material who require a market-leading weighing solution, the Ishida Cut-gate Weigher provides an exceptional high accuracy, high speed weighing solution which will significantly reduce downtime, product giveaway and increase profits. A range of hopper sizes are available to handle a wide range of target weights.

Dimensions

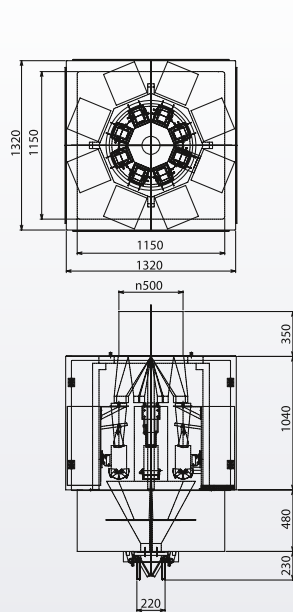

CG-R202LC-8R

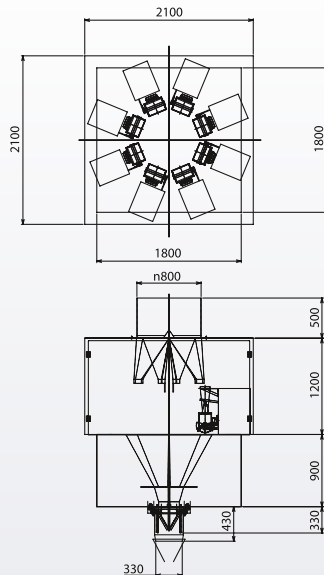

CG-R203LC-8R

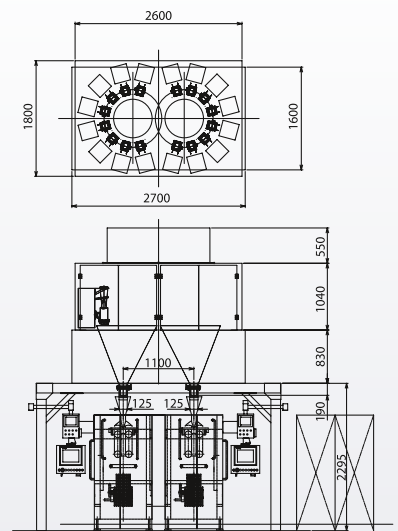

CG-R202LC-16R

| Specifications | CG-R202LC-8R | CG-R203LC-8R | CG-R202LC-16R |
|-----------------------|---------------|-----------------|----------------------------|
| Head Count | 8 | 8 | 16 |
| Target Weighing Range | 100g - 1,000g | 1,000g - 3,000g | 100g - 1,000g |
| Weighing Speed | Up to 120 WPM | Up to 80 WPM | Up to 240 WPM (2x 120 WPM) |

CG-R Series features and benefits

The CG-R Series is the high speed, higher performance Ishida cut-gate weigher designed to weigh granular application products very accurately. The simple design and application pre-sets make the CG-R Series fast and easy to use as an in-line solution.

Precise weighing accuracy

Highly accurate Ishida load cell and high-speed feedback control system allows stable and accurate weighing. Significantly reducing giveaway compared to conventional methods.

Gentle product handling

Compared with auger or volumetric cup fillers, the cut-gate feeding system dramatically reduces product damage and minimises product giveaway.

Easy to clean

No tools are required to remove cut-gate, weigh hopper and many other parts, simplifying clean-up procedures and reducing clean-up time.

Dustproof construction

To prevent dust dispersion, weighing components are enclosed in an easily detachable cover. A sealed enclosure for gas flushing is available as an option.

Quick product changeover

Target weight, weighing speed and other settings are easy to change via the Remote Control Unit.

Options

- Stainless body construction
- CF card slot
- Data printer
- Communication interface



Precise opening and closing control



7 inch colour touchscreen displays performance data

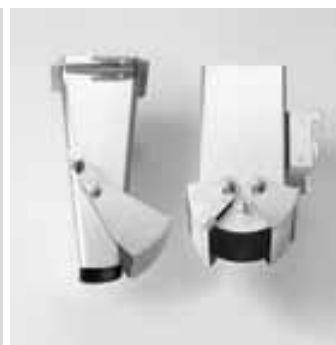

Weigh hopper and cut-gate respectively, removed without use of tools



For highly accurate weighing of dry, free-flowing granular product

ISHIDA EUROPE LIMITED

Kettles Wood Drive
Woodgate Business Park
Birmingham
B32 3DB
United Kingdom
Tel: +44 (0)121 607 7700
Fax: +44 (0)121 607 7888
info@ishidaeurope.com

ISHIDA CZECH REPUBLIC

Tel: +420 317 844 059
Fax: +420 317 844 052
info@ishidaeurope.cz

ISHIDA ROMANIA

Tel: +40 (0)21 589 73 52
Fax: +40 (0)21 310 34 22
info@ishidaeurope.ro

ISHIDA FRANCE

Tel: +33 (0)1 48 63 83 83
Fax: +33 (0)1 48 63 24 29
info@ishidaeurope.fr

ISHIDA RUSSIA AND CIS

Tel: +7 499 272 05 36
Fax: +7 499 272 05 37
info@ishidaeurope.ru

ISHIDA GERMANY

Tel: +49 (0)791 945 160
Fax: +49 (0)791 945 1699
info@ishida.de

ISHIDA SOUTH AFRICA

Tel: +27 (0)11 976 2010
Fax: +27 (0)11 976 2012
info@ishidaeurope.com

ISHIDA MIDDLE EAST

Tel: +971 (0)4 299 1933
Fax: +971 (0)4 299 1955
ishida@ishida.ae

ISHIDA SWITZERLAND

Tel: +41 (0)41 799 7999
Fax: +41 (0)41 790 3927
info@ishida.ch

ISHIDA NETHERLANDS

Tel: +31 (0)499 39 3675
Fax: +31 (0)499 39 1887
info@ishida.nl